

400 Hz Fans

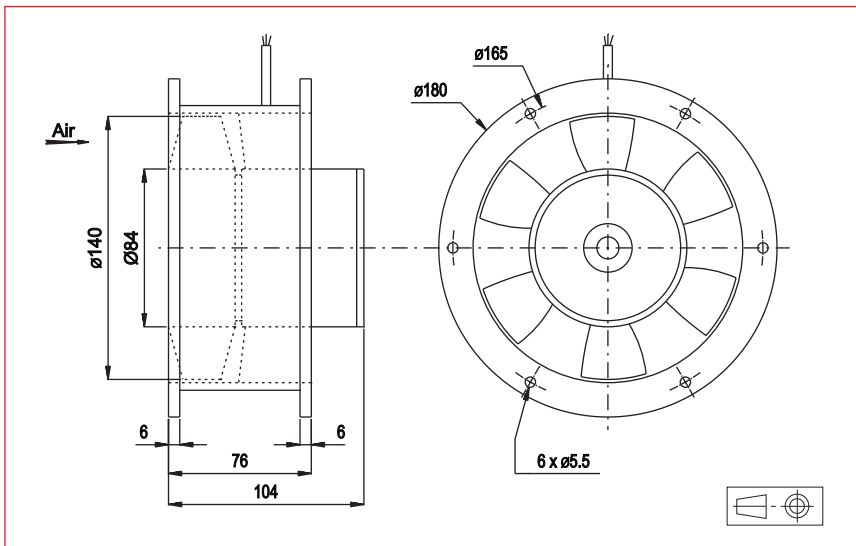

Approvals

NATO codification (not on all part numbers, please consult the factory for more detailed information)

Life expectancy

L-10 LIFE AT 40°C:
25 000 hours

400 Hz Motor

Housing material: aluminium
Impeller material: aluminium
Weight: 2,6 kg
Bearing system: ball bearings

Connection: flying leads

Available with:

- safety switch
- Single phase (80MZ)

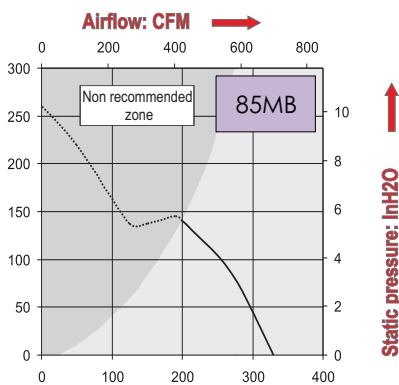
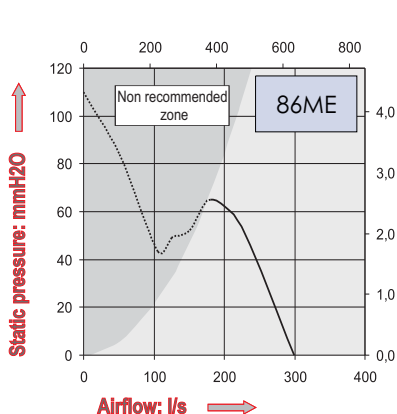

Part Number	Nominal voltage	Airflow		Noise level	Nominal speed	Phases	Capacitor (not included)	Input power	Nominal Current	Starting Current	Operating temperature	
	V	l/s	Cfm	dB(A)	RPM		µF	W	mA	mA	Min.°C	Max.°C
86ME0162C13	115	300	635,7	80	7400	3		400	3700	10000	-10	70
86ME0160C13	200	300	635,7	80	7400	3		400	2100	5700	-10	70
85MB0160C13	200	330	699,3	90	11000	3		660	2750	1100	-10	70
85MB0162C13	115	330	699,3	90	11000	3		660	4800	1900	-10	70

Additional versions:
Salt spray protected - Shock and vibration protected - Thermally protected - Marine specifications - Wide temperature range