

400 Hz Fans



Approvals

NATO codification (not on all part numbers, please consult the factory for more detailed information)

Life expectancy

L-10 LIFE AT 40°C:
35 000 hours

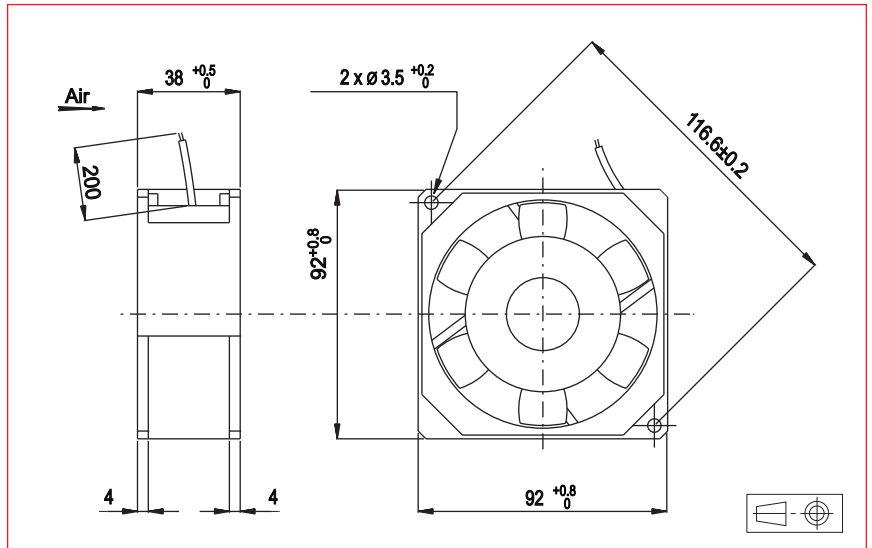

400 Hz Motor

Housing material: aluminium
Impeller material: plastic UL 94 VO
Weight: 480 g
Bearing system: ball bearings

Connection: flying leads

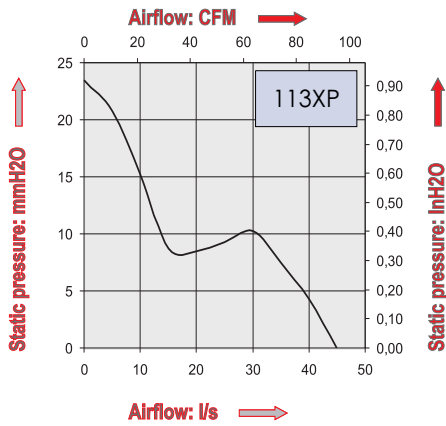

Part Number	Nominal voltage	Airflow		Noise level dB(A)	Nominal speed RPM	Phases	Capacitor (not included) µF	Input power W	Nominal Current mA	Starting Current mA	Operating temperature	
	V	l/s	Cfm								Min.°C	Max.°C
113XP0162001	115	45	95,3	58	5500	3		19	180	435	-10	70
	115	45	95,3	58	5500	1	0,69	20	200	350	-10	70
113XP0160001	200	45	95,3	58	5500	3		19	105	250	-10	70
	200	45	95,3	58	5500	1	0,22	20	110	200	-10	70

Additional versions:
Salt spray protected - Shock and vibration protected - Marine specifications
Wide temperature range

