

400 Hz Fans



Approvals

NATO codification (not on all part numbers, please consult the factory for more detailed information)

Life expectancy

L-10 LIFE AT 40°C:
35 000 hours

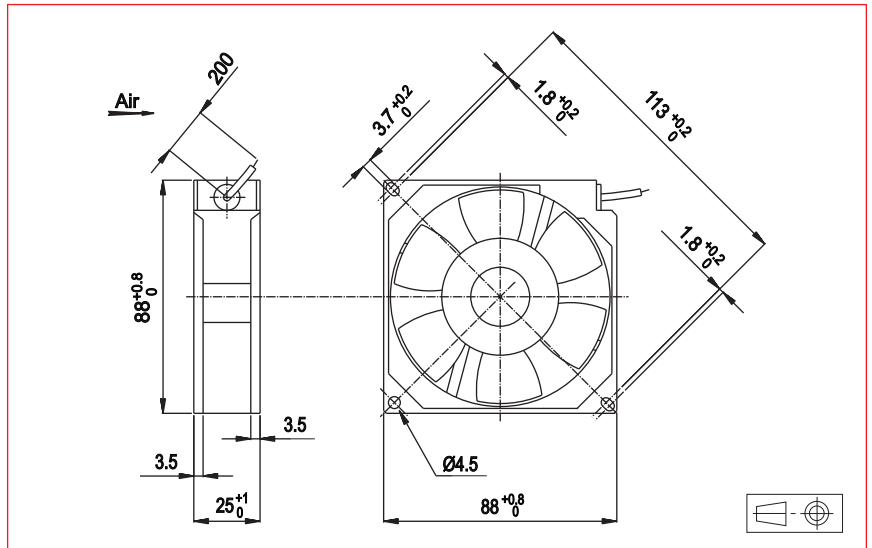

400 Hz Motor

Housing material: aluminium
Impeller material: plastic
Weight: 200 g
Bearing system: ball bearings

Connection: flying leads

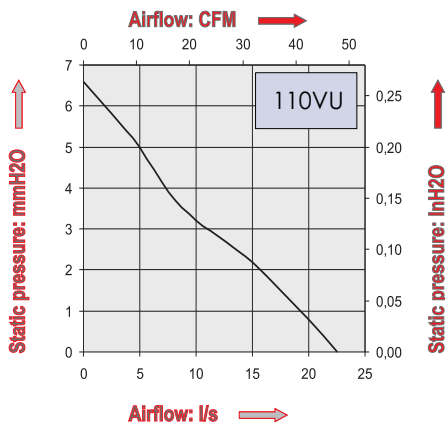

Part Number	Nominal voltage	Airflow		Noise level dB(A)	Nominal speed RPM	Phases	Capacitor (not included) µF	Input power W	Nominal Current mA	Starting Current mA	Operating temperature	
	V	l/s	Cfm								Min.°C	Max.°C
110VU0162001	115	22,5	47,7	43	3300	1	0,47	14	130	140	-10	70
110VU0160001	200	22,5	47,7	43	3300	1	0,15	14	75	80	-10	70

Additional versions:
Salt spray protected - Shock and vibration protected - Impedance protected -
Marine specifications - Wide temperature range