

400 Hz Fans

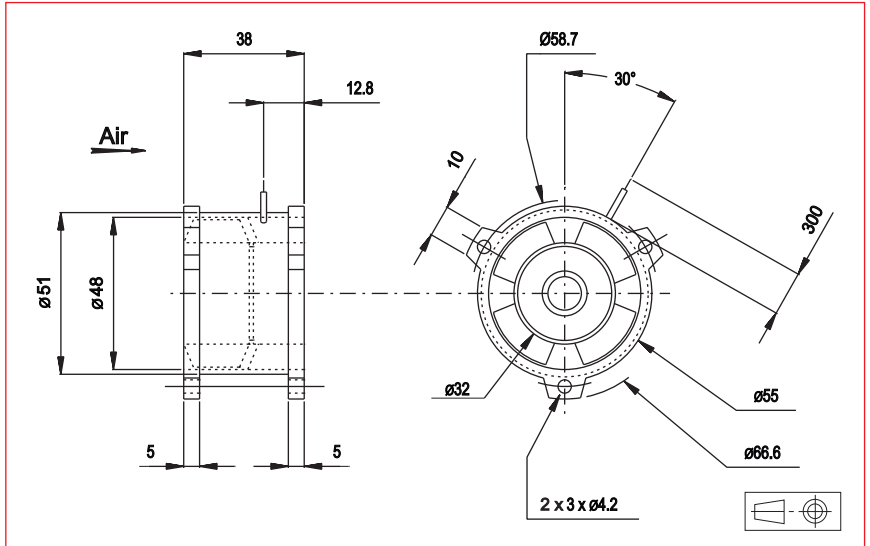

Approvals

NATO codification (not on all part numbers, please consult the factory for more detailed information)

Life expectancy

L-10 LIFE AT 40°C:
25 000 hours

400 Hz Motor

Housing material: aluminium
Impeller material: aluminium
Weight: 170 g
Bearing system: ball bearings

Connection: flying leads

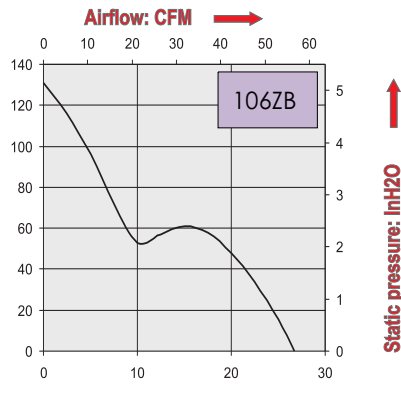
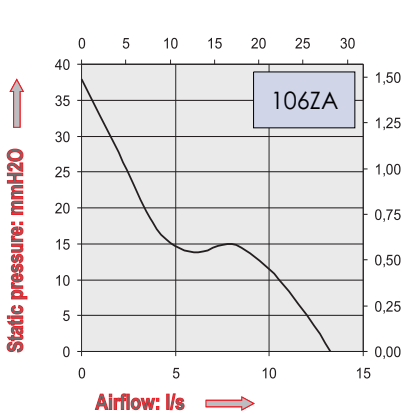

Part Number	Nominal voltage	Airflow		Noise level	Nominal speed	Phases	Capacitor <small>(not included)</small>	Input power	Nominal Current	Starting Current	Operating temperature	
	V	l/s	Cfm	dB(A)	RPM		µF	W	mA	mA	Min.°C	Max.°C
106ZA0562C13	115	13	27,5	51	11500	3		15	160	350	-10	70
	115	13	27,5	51	11500	1	0,47	15	180	350	-10	70
106ZA0560C13	200	13	27,5	51	11500	3		15	95	205	-10	70
	200	13	27,5	51	11500	1	0,15	15	105	205	-10	70
106ZB0562C13	115	27	57,2	72	22700	3		51	325	1250	-10	70
106ZB0560C13	200	27	57,2	72	22700	3		42	195	720	-10	70
	200	27	57,2	72	22700	1	0,32	43	215	455	-10	70

Additional versions:

Salt spray protected - Shock and vibration protected - Thermally protected
Marine specifications - Wide temperature range